

2

1

PROPRIETARY AND CONFIDENTIAL
 THE INFORMATION CONTAINED IN THIS DRAWING IS THE SOLE PROPERTY OF NEUTRONICS ENTERPRISES INC. AND SHALL NOT BE COPIED, DISCLOSED TO THIRD PARTIES, OR USED FOR ANY PURPOSE OTHER THAN THE SPECIFIC PURPOSE FOR WHICH IT WAS PROVIDED. ANY REPRODUCTION IN PART OR AS A WHOLE WITHOUT THE WRITTEN AUTHORIZATION OF NEUTRONICS ENTERPRISES INC. IS PROHIBITED.

REVISION HISTORY			
REV.	DESCRIPTION	DATE	APPROVED
2024A	INITIAL RELEASE	05/07/2024	JK

SECTION A-A

SCALE 1 : 2.25

B

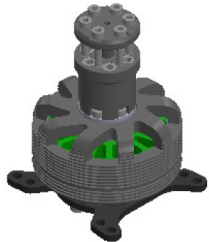

60° PATTERN THREAD
 M6 x Ø 29.00 [1.142]
 IN SHAFT HEAD

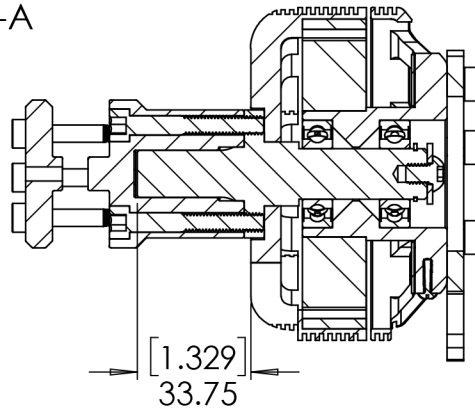
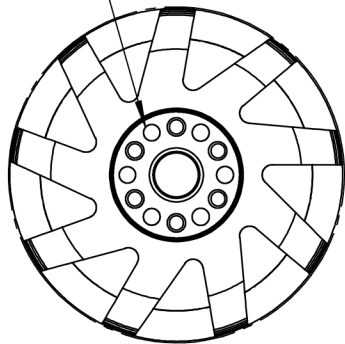

2X 60° PATTERN THREADS
 M5 x Ø 55.00 [2.165]
 M5 x Ø 57.15 [2.250]

B

A

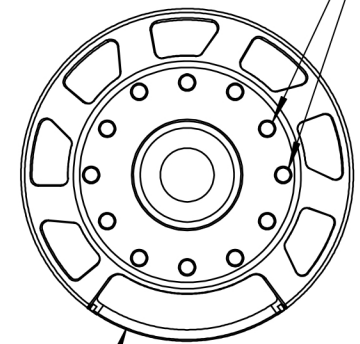
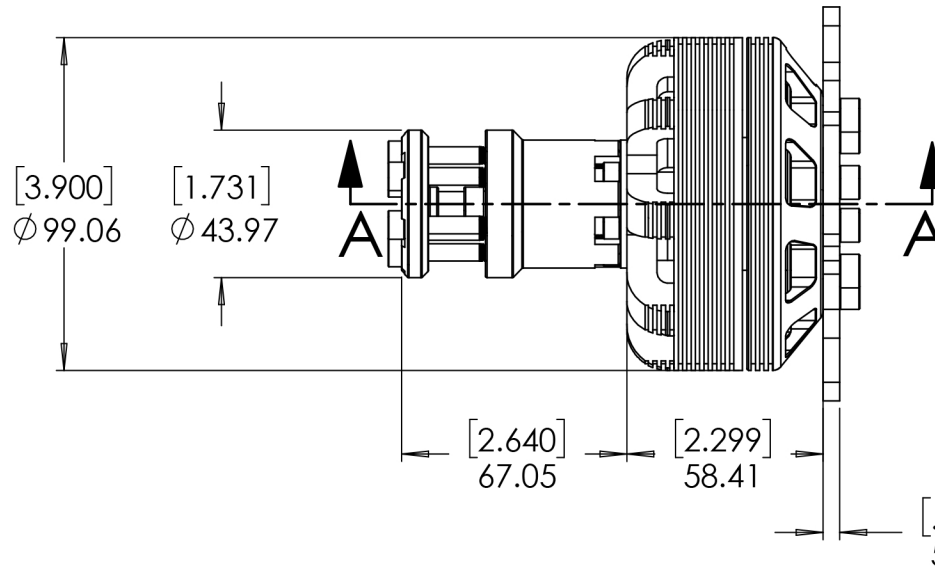

WIRES EXIT HERE

A

NOTES

1. DIMENSIONS ARE IN MM AND [IN]
2. TOLERANCES +/- 0.05mm UNLESS OTHERWISE SPECIFIED
3. DIMENSIONS AND TOLERANCES APPLY AFTER FINISHING

NEUMOTORS

TITLE: W8019 ASSY PROFILE - STANDARD MOUNT	REV: 2024A
https://neumotors.com/	info@neutronics.com

SHEET 1 OF 1

2

1

2

1

PROPRIETARY AND CONFIDENTIAL
 THE INFORMATION CONTAINED IN THIS DRAWING IS THE SOLE PROPERTY OF NEUTRONICS ENTERPRISES INC. AND SHALL NOT BE COPIED, DISCLOSED TO THIRD PARTIES, OR USED FOR ANY PURPOSE OTHER THAN THE SPECIFIC PURPOSE FOR WHICH IT WAS PROVIDED. ANY REPRODUCTION IN PART OR AS A WHOLE WITHOUT THE WRITTEN AUTHORIZATION OF NEUTRONICS ENTERPRISES INC. IS PROHIBITED.

REVISION HISTORY			
REV.	DESCRIPTION	DATE	APPROVED
2024A	INITIAL RELEASE	05/07/2024	JK

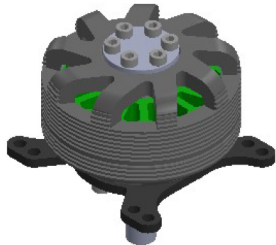

B

B

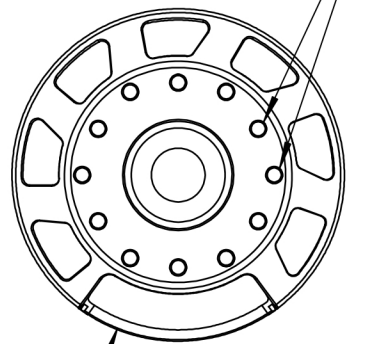
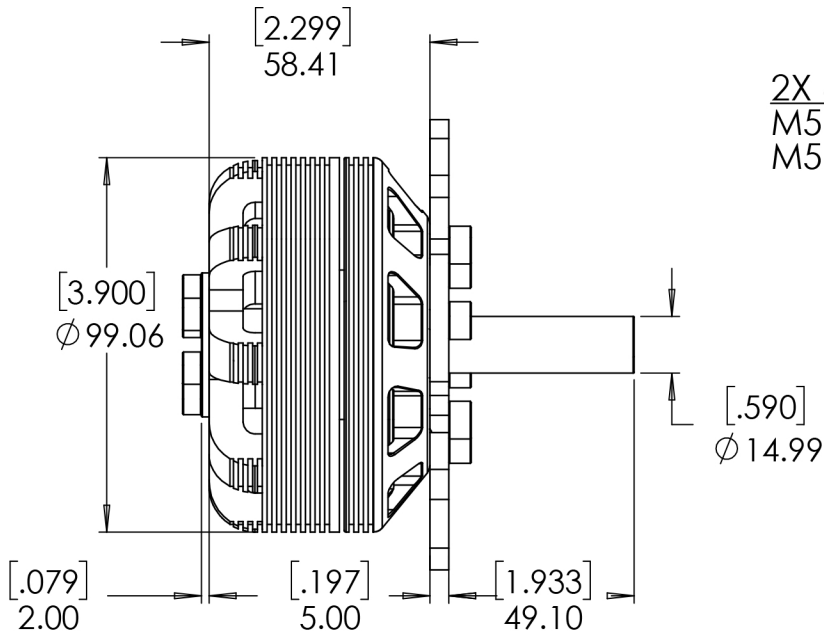
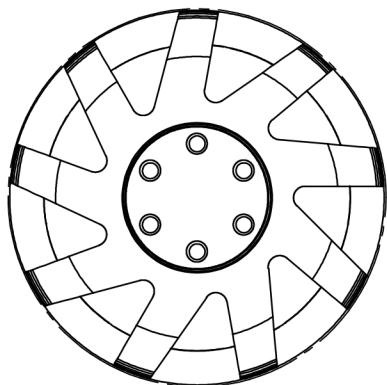

WIRES EXIT HERE

A

A

- NOTES
1. DIMENSIONS ARE IN MM AND [IN]
 2. TOLERANCES +/- 0.05mm UNLESS OTHERWISE SPECIFIED
 3. DIMENSIONS AND TOLERANCES APPLY AFTER FINISHING

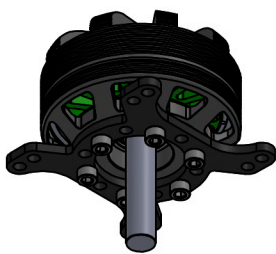

NEUMOTORS

TITLE: W8019 ASSY PROFILE - REAR MOUNT	REV: 2024A
https://neumotors.com/	info@neutronics.com SHEET 1 OF 1

2

1